

Before you start, **read these instructions first** to understand what you need to do to install this product.

These **Telecaster Control Plate** Upgrade products are designed to control 2, 3 or 4 magnetic pickup coils. **Note:** *Active* (uses batteries) or *Pizeo* pickups cannot be used with our upgrade products.

Tools Needed

You may need one or more of the following tools (*not included with purchase*) to install your upgrade product.

- Wire cutters / Wire strippers
- Regular pliers
- Small Phillips & straight slot screwdriver
- Ohmmeter to measure continuity
- Optional: rotary file and electric drill
- Optional: Soldering iron (25/30 watt max.) with fine tip, rosin-core solder .022" dia.

Preamble

Although not required for this product, you might want to completely **remove all strings** from your instrument for easy access to its parts. The strings are probably already old and replacing them will make your instrument sound even more *brilliant* after you install this product.

Your **Telecaster Control Plate** Upgrade will have you cutting existing wires on your instrument. You may need to make wire connections, increase the length of existing wires, and remove some wood in your instrument body cavity.

Because you will be making several changes to your instrument, you need to have a plan to install this Telecaster upgrade.

See the *Reference Drawing* on a later page of this document. Use a pencil to draw the original circuit of your instrument **before** you proceed. When you record

where the wires (and colors) were removed from your instrument, you have a way to restore it to its original condition should it become necessary. Since there is a large variation of pickup switch wiring that spans 50 years, you will need to draw your own pickup switch used in your original circuit

Adding Extra Wire

If your pickup or output wires are too short to easily reach the specified connection of the green terminal strip on the **Telecaster Control Plate** Upgrade circuit board, here is what to do. Measure out the needed length of the RED or BLACK wire in the included **PARTS BAG** to permit the wire to reach the applicable connection. A length of 3" (7.62cm) is budgeted for each wire extension. Insert the **unstripped** end of each wire into the 2-wire UY2 **yellow/clear** connector and clamp down using regular pliers.

Use pliers to squeeze the UY2 connector top button so it is flush with the body to create a permanent electrical connection. Verify electrical continuity between the two pickup wires using an ohmmeter (some coil resistance will be present). The 71B **grey wire nuts** are used to make firm and insulated connection to the output jack wires, but let you easily disconnect the upgrade if needed.

Note: If either your pickup or output wires use a shielded/braided cable, you will need to solder black wire to the cable because the **green** terminal strip (J1) does not directly accept shielded cable.

Product Variants

This document contains information in separate sections that is specific for the following upgrade products for your Telecaster (or clone) guitar.

1. TCP-T2: for a stock 2-pickup Tele
2. TCP-T3: for a stock Nashville Tele
3. TCP-T4: for an HSS or HH Tele

TELECASTER UPGRADE

You have received an assembled and tested **Telecaster Upgrade** designed to install into a standard American Telecaster guitar. It contains one of our *high performance* **Telecaster Control Plate Upgrade** products, one tone and volume control with matching knobs. It uses your existing pickups to give you more pickup tones. No soldering is needed to install this product. The following items are included in a Parts Bag.

- Several business cards to pass out to friends
- An equal length each of black and red insulated wire (to lengthen pickup and output jack wire if needed)
- 2 or 4 yellow/clear connectors (UY2) to make pickup wire extension connections if needed
- 2 grey wire nuts (71B) to connect output jack wires to your Telecaster control plate upgrade product

Preparation

If needed, remove your strings. Remove your existing control plate attaching screws. Lift it out and document how your instrument is wired (see *Preamble* on page 1) *before* you start this upgrade.

Disconnect the **output jack** hot and ground wires from your stock control plate. The wires stay on the output jack.

Cut the **pickup wires** from the 3-way (or 5-way) pickup switch so all wires are of maximum length. If needed, disconnect the bridge ground wire. Remove your original control plate. Temporarily stow the output jack wires and pickup wires within the body cavity.

Confirm that the **Telecaster Upgrade** will lay completely flat and within the routed body cavity with no interference by the wood body. If the **Telecaster Upgrade** lays flat on your instrument and the plate mounting holes line up with the body mounting holes, proceed to the next section, *Terminal Strip*, to continue with the upgrade process.

If your instrument has a control plate body cavity with a non-standard dimension preventing the upgrade product from being installed flush against the body, *see page 11 – Solving Installation Issues* for help.

Terminal Strip

Here is how to attach wires to the **green** terminal strip (J1) that is on the circuit board. Use a small screwdriver or writing pen tip and press down on the square *release button* located directly above the wire hole. Hold the button down and insert the stripped wire completely into the wire connection hole and then release the button. Lightly tug on the wire to confirm it is firmly gripped by the Terminal Strip. A legend is printed on the circuit board with the name of each terminal strip wire hole from left to right. Attach each wire to the correct terminal strip hole. Before shipping your upgrade, the factory has attached the wires from the Volume-Tone control to the **GND** and **VOL** wire terminal strip holes.

T2-Switch (6-hole terminal strip): [GND] [VOL] [+]Coil-2[-] [+]Coil-1[-]

T3Plus-Switch (8-hole terminal strip): [GND] [VOL] [+]Coil-3[-] [+]Coil-2[-] [+]Coil-1[-]

T4-Switch (10-hole terminal strip): [GND] [VOL] [+]Coil-4[-] [+]Coil-3[-] [+]Coil-2[-] [+]Coil-1[-]

Caution: Do not insert hard items in the wire holes because it will decrease reliable electrical connection.

Connecting Your Wires

There is no industry standard for pickup wire lead colors. More common color pairs are red/black, red/white, black/white and white/shield. You are advised to use consistency when connecting *your* pickup wire color pairs to the [+] and [-] pickup connections on the **green** terminal strip (J1).

Determine which wire color for each pickup coil will be attached to the applicable [+] and [-] **green** terminal strip connector on the circuit board. If one of the pickup wire connections is a shielded lead, always connect the shield to a BLACK [-] wire to be inserted in the green terminal strip on our switching system.

Determine if there is enough wire length from each 2-wire pickup coil to *comfortably* reach the corresponding connectors on the green terminal strip on the **Telecaster Control Plate Upgrade** circuit board. If not, refer to the “*Adding Extra Wire*” topic (page 1).

WARNING: If your pickups have a metal bottom and if either pickup coil wire is grounded to this housing (use an ohmmeter to check each wire to body), make sure your instrument’s body cavity is not lined with grounded metal shielding and the pickup housing does not have a separate grounding wire.

Reason: This will cause the pickup to “short” to ground when the pickup switch is put into the regular/reverse phase. To fix this, isolate the pickup housing from the body cavity shielding with soft foam.

Strip off 3/16” (4.76mm) insulation from the end of each pickup wire and also the output jack wires then twist the exposed wire strands so they are tightly bound. Optionally, use a soldering iron to lightly "tin" the wires. Insert the bare wire ends of each pickup pair into the correct location on the **green** terminal strip (J1) using the process described in the above “*Terminal Strip*” topic. Also refer to the following instructions for your specific upgrade.

Use the two gray wire nuts (71B) to connect the wires labeled “Output Jack” to the wires on your **output jack**. The red wire goes to the hot lead (normally red) on the output jack and the black wire goes to the ground lead on the output jack.

Note: If you have a ground wire coming from the bridge (and maybe from body cavity shielding), connect it to the ground lead on the output jack.

Connecting your pickups to the TCP-T2 Telecaster Upgrade (uses our T2-Switch)

This upgrade is for a standard Telecaster with two single-coil pickups or similar instruments.

Connect your **NECK** pickup coil wire pair to the [+]Coil-2[-] connections on the green terminal strip
Connect your **BRIDGE** pickup coil wire pair to the [+]Coil-1[-] connections on the green terminal strip

TCP-T2 Telecaster Upgrade Switch Identification and Use Summary

Here is a summary of switch use for this product (see **Figure 1** for switch identification).

Our T2 Switch mapping document will help you “map” the pickup tones you get from the T2-Switch. It is available for download from our website’s Document Library at <http://www.AweSome-Guitars.com>

SW1 and SW3 are ON-OFF-ON switches that turn on individual pickups in normal or reverse phase
SW5 is an ON-ON switch that changes the pickups from *Parallel* to *Series* connectivity

Switch Use:

SW1 turns on the **bridge** pickup, either in normal phase (down), or reverse phase (up).

SW3 turns on the **neck** pickup, either in normal phase (down), or reverse phase (up).

SW5 When this switch is **down**, the pickups will be in a *Parallel* circuit.

When this switch is **up** it puts the **bridge** and **neck** pickups in a *Series* circuit. Both pickups must be on, either in normal phase(down) or reverse phase (up) or no sound will be produced.

Special Note: For easy identification, switches now have colored covers: White for pickup coil switches, Black for parallel-series switches.

Connecting your pickups to the TCP-T3 Telecaster Upgrade (uses our T3Plus-Switch)

This upgrade is for Nashville Telecasters with three single-coil pickups or similar instruments.

Connect your NECK pickup coil wire pair to the	[+]Coil-3[-]	connections on the green terminal strip
Connect your MIDDLE pickup coil wire pair to the	[+]Coil-2[-]	connections on the green terminal strip
Connect your BRIDGE pickup coil wire pair to the	[+]Coil-1[-]	connections on the green terminal strip

TCP-T3 Telecaster Upgrade Switch Identification and Use Summary

Here is a summary of switch use for this product (see **Figure 1** for switch identification).

Our T3Plus Switch mapping document will help you “map” the pickup tones you get from the T3Plus-Switch. It is available for download from our website’s Document Library at <http://www.AweSome-Guitars.com>

SW1, SW2 and SW3 are ON-OFF-ON switches that turn on individual pickups in normal or reverse phase
SW4, SW5 and SW6 are ON-ON switches that change select pickups from *Parallel* to *Series* connectivity

Switch Use:

SW1 turns on the **bridge** pickup, either in normal phase (down), or reverse phase (up).
SW2 turns on the **middle** pickup, either in normal phase (down), or reverse phase (up).
SW3 turns on the **neck** pickup, either in normal phase (down), or reverse phase (up).

*When all of the following switches are **down**, the pickups will be in a Parallel circuit.*

SW4 when switch is **up** it puts the **bridge** and **middle** pickups in *Series*. Both pickups must be on.¹
SW5 when switch is **up** it puts the **bridge** and **neck** pickups in *Series*. Both pickups must be on.¹
SW6 when switch is **up** it puts the **neck** and **middle** pickups in *Series*. Both pickups must be on.¹
SW4+SW6 when these switches are **up**, all three pickups in *Series*. All pickups must be on or no sound will be produced. In this switch combination, SW5 has no effect.

¹ The remaining *non-series* pickup may be either off -or- on (either in regular or reverse phase).

Special Note: For easy identification, switches now have colored covers: White for pickup coil switches, Black for parallel-series switches.

Connecting your pickups to the TCP-T4 Telecaster Upgrade (uses our T4-Switch)

This upgrade is for HSS or HH instruments with true 4-wire humbucker pickups.

If you are using two 4-wire humbucker pickups:

Connect your NECK2 pickup coil wire pair to the	[+]Coil-4 [-]	connections on the green terminal strip ²
Connect your NECK1 pickup coil wire pair to the	[+]Coil-3 [-]	connections on the green terminal strip ²
Connect your BRIDGE2 pickup coil wire pair to the	[+]Coil-2 [-]	connections on the green terminal strip ¹
Connect your BRIDGE1 pickup coil wire pair to the	[+]Coil-1 [-]	connections on the green terminal strip ¹

If you are using two single-coil pickups and one 4-wire humbucker pickup:

Connect your NECK pickup coil wire pair to the	[+]Coil-4 [-]	connections on the green terminal strip
Connect your MIDDLE pickup coil wire pair to the	[+]Coil-3 [-]	connections on the green terminal strip
Connect your BRIDGE2 pickup coil wire pair to the	[+]Coil-2 [-]	connections on the green terminal strip ¹
Connect your BRIDGE1 pickup coil wire pair to the	[+]Coil-1 [-]	connections on the green terminal strip ¹

¹ Assumes that the bridge pickup position contains a 4-wire humbucker pickup

² Assumes that the neck pickup position contains a 4-wire humbucker pickup

TCP-T4 Telecaster Upgrade Switch Identification and Use Summary

Here is a summary of switch use for this product (see **Figure 1** for switch identification).

Our T4 Switch mapping document will help you “map” the pickup tones you get from the T4-Switch. It is available for download from our website’s Document Library at <http://www.AweSome-Guitars.com>

SW1, SW2, SW3 and SW3 are ON-OFF-ON switches to turn on individual pickups in normal or reverse phase
S5N and S5B are ON-ON switches that change select pickup coils from *Parallel* to *Series* connectivity

Switch Use:

SW1 turns on **BRIDGE1** pickup coil, either in normal phase (down), or reverse phase (up).

SW2 turns on **BRIDGE2** pickup coil, either in normal phase (down), or reverse phase (up).

S5B When this switch is **down**, both bridge pickup coils will be in a *Parallel* circuit.

When this switch is **up** it puts **BRIDGE1** and **BRIDGE2** pickup coils in a *Series* circuit. Both pickup coils must be on, either in normal phase (down) or reverse phase (up) or no sound will be produced.

SW3 turns on **NECK1** pickup coil, either in normal phase (down), or reverse phase (up).

SW4 turns on **NECK2** pickup coil, either in normal phase (down), or reverse phase (up).

S5N When this switch is **down**, both neck pickup coils will be in a *Parallel* circuit.

When this switch is **up** it puts **NECK1** and **NECK2** pickup coils in a *Series* circuit. Both pickup coils must be on, either in normal phase (down) or reverse phase (up) or no sound will be produced.

Special Note: For easy identification, switches now have colored covers: White for pickup coil switches, Black for parallel-series switches.

Validating

Connect your instrument to an amplified source with the volume set to low. Turn the switches on and off as described in “*Switch Identification and Use Summary*” topic while gently tapping the magnet of the pickup coil that should be “on” with a small screwdriver to confirm pickup response. Also confirm the correct operation of the Volume and Tone controls.

If you receive the stated results, install the **Telecaster Control Plate** Upgrade mounting hole screws. Next, install a new set of strings. Welcome to the *Grand Canyon Wide* range of AweSome pickup tones.

These are products that give your 2-pickup coil, 3-pickup coil and 4-pickup coil instruments a HUGE spectrum of sounds ranging from Muddy/Dirty Blues -to- Classic Jazz -to- Heavy Metal -to- Ring-in-a-bell Surf -to- Intense Country Twang and will even give you those elusive out-of-phase *Tin-Canny* pickup tones. After this upgrade is installed, you can duplicate the sound of virtually every electric guitar ever made! This product will produce a wide spectrum of unique pickup sounds that you have NEVER even heard before.

Figure 1 – Telecaster Upgrade Mounting Orientation and Switch Identification

The following image identifies the each of the switches for the control plate.

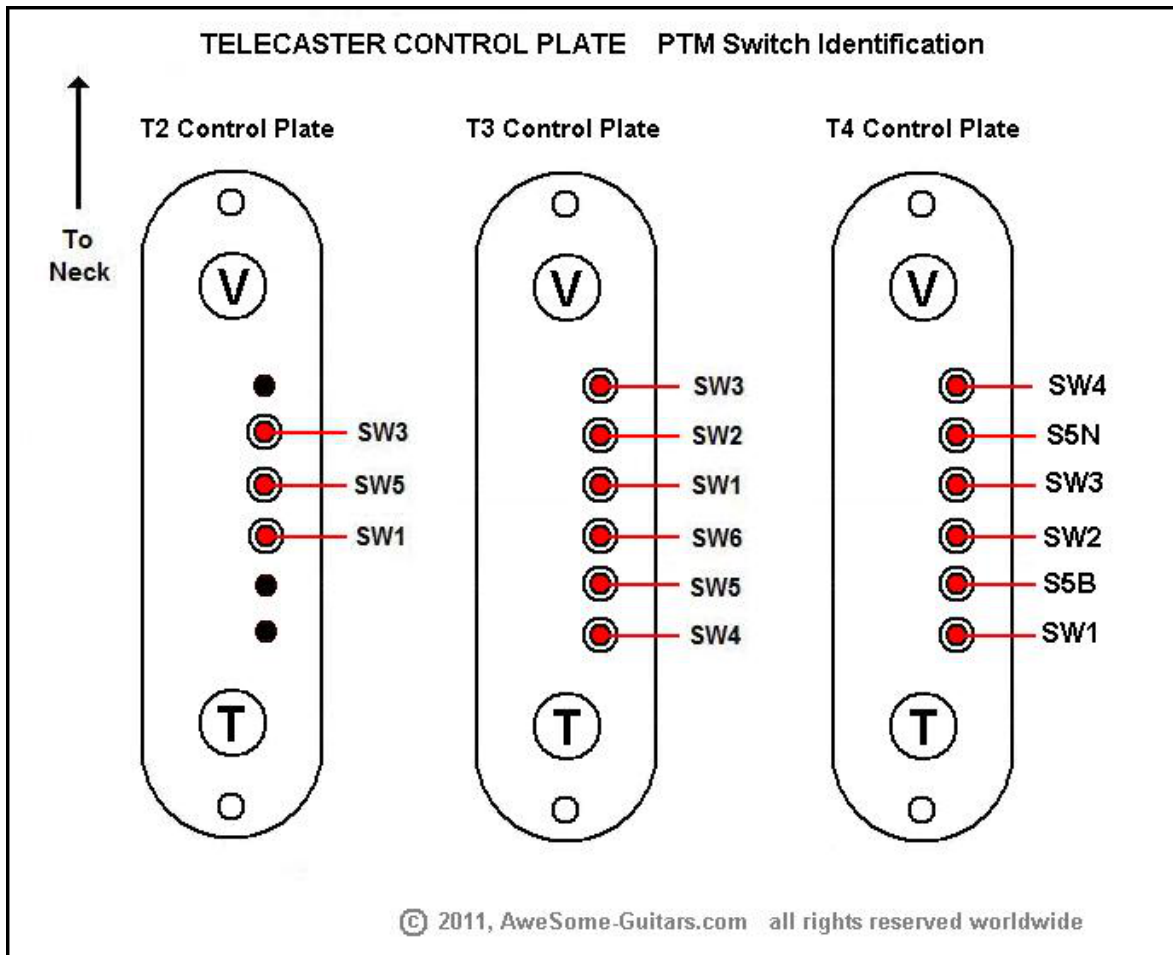
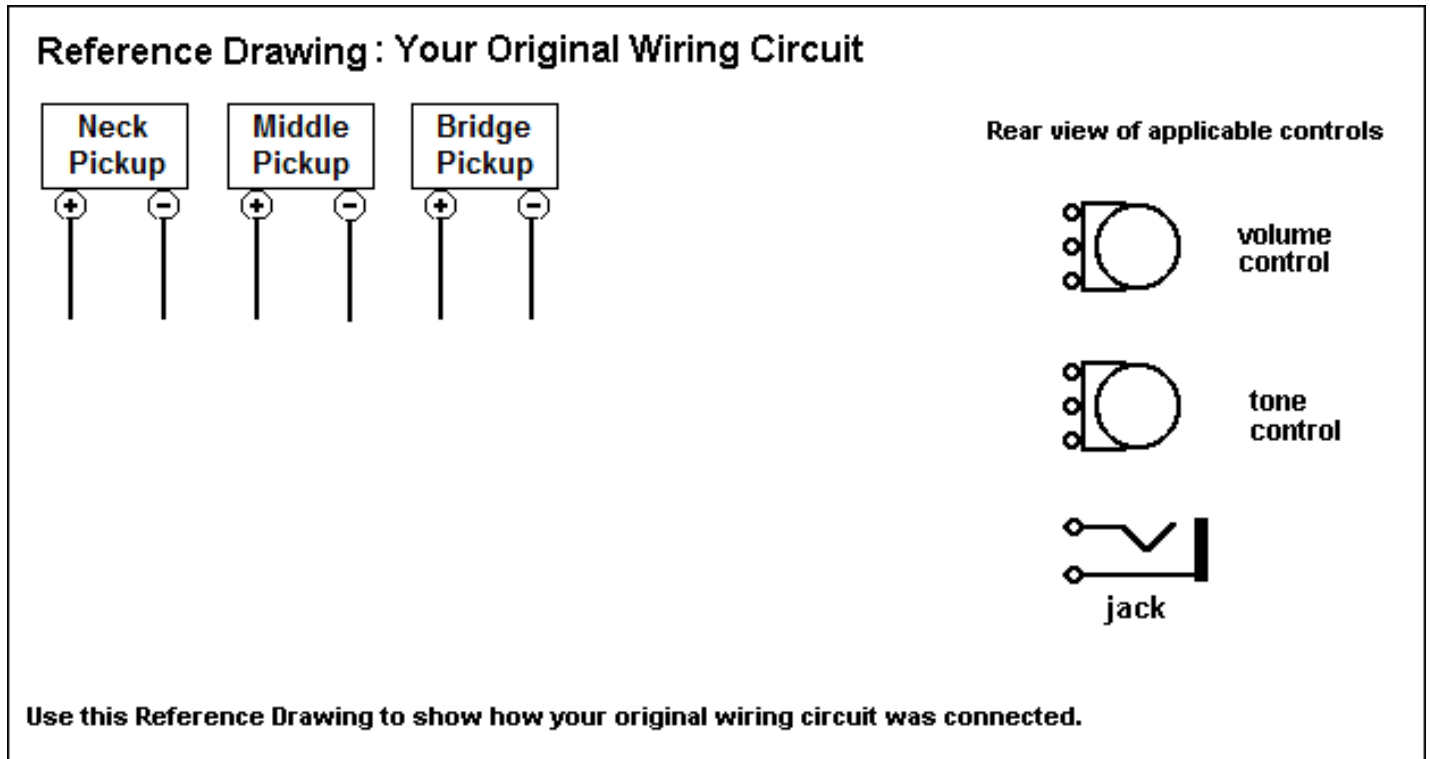

Figure 2 – Reference Drawings

Use the following image to document your instrument's original wiring. Be sure to identify wire colors where needed. Use a pencil when doing this. You need to draw the pickup switch in your instrument.



The below drawing identifies where to connect your pickups and output jack to our **Telecaster Upgrade**. The Volume-Tone Control includes our **Pro Treble Bleed** to keep your brilliance even at low volume levels.

Suggested Volume-Tone Wiring for use with

terminal strip connection guide

VT-2 (Volume/Tone Control)
RIGHT-HAND WIRING

⏏ areas marked with this symbol MUST be electrically connected

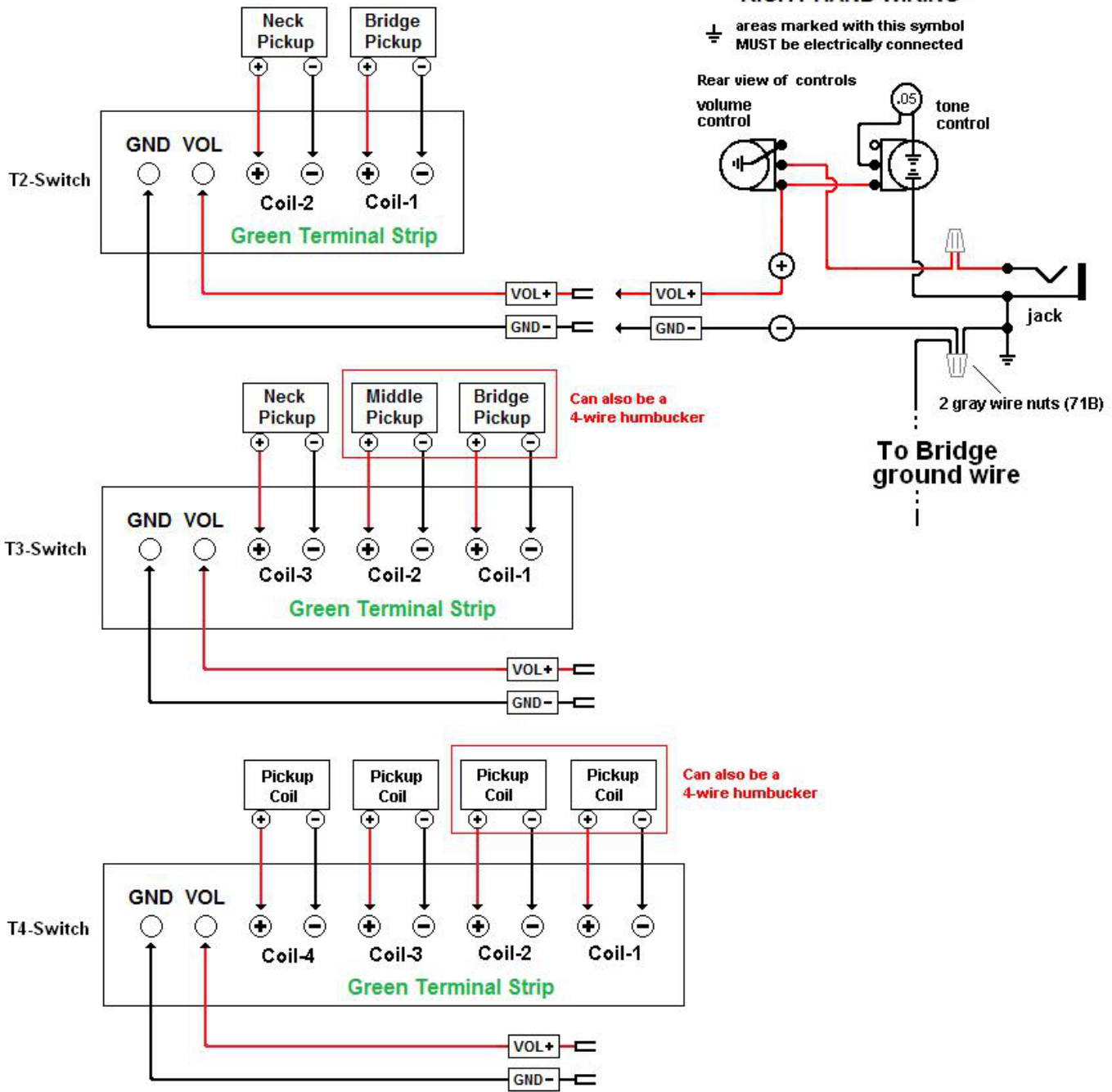

(C) 2011 AweSome Musical Instruments, All rights reserved worldwide www.AweSome-Guitars.com

Solving Installation Issues

Here is how to solve installation issues that involve insufficient body cavity width and/or depth.

1. The **Telecaster Control Plate Upgrade** does not fit into the body cavity because of there is not enough room.

Because Fender never imposed rigorous standards on their manufacturing *partners* in China, Malaysia, Mexico, Indonesia, Korea, India, etc., some instruments were made with a control plate body cavity that is slightly smaller than the cavity in the *standard* American instruments. Further, some instruments may have a body cavity depth with two different levels and may require some material removal so the plate of the Telecaster Upgrade will completely lay flat on the body.

To solve these body cavity width and depth issues, you can use a power drill with a rotary file to remove a small amount of material on either side of the body cavity. You should only remove enough material to permit installation. Typically, removing 1/32" off each side will be adequate to solve this issue.

The below illustration shows you how to use the electric drill and rotary file bit to remove excess material on each side of the body cavity. Also illustrated are two common rotary file bits. The top one is a rasp bit, the lower one is a scraping bit. Either will work.

When using this procedure, it is recommended that you enlist the help of a friend to firmly hold the guitar body while removing the unneeded wood using the rotary file. Using a blanket or other material between the guitar body and the working surface will prevent the bottom of the body from being scratched.

